

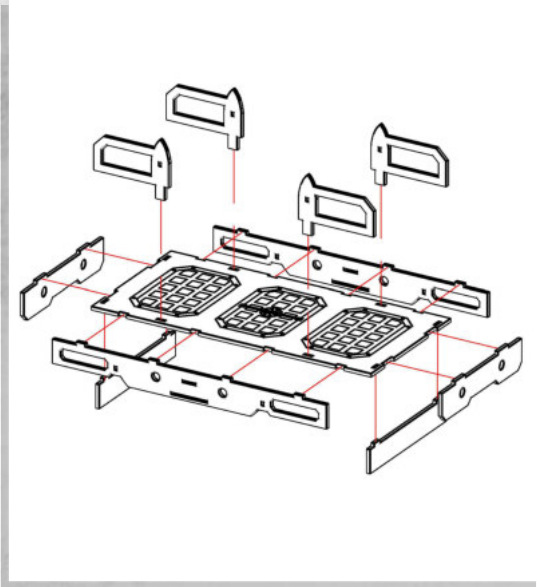

Dark Assembly Bridge - Assembly Guide

Parts may need careful removal from the MDF boards with a scalpel, and light sanding of any rough edges. We recommend testing assembling sections before permanently gluing together.



Walkway Assembly 1

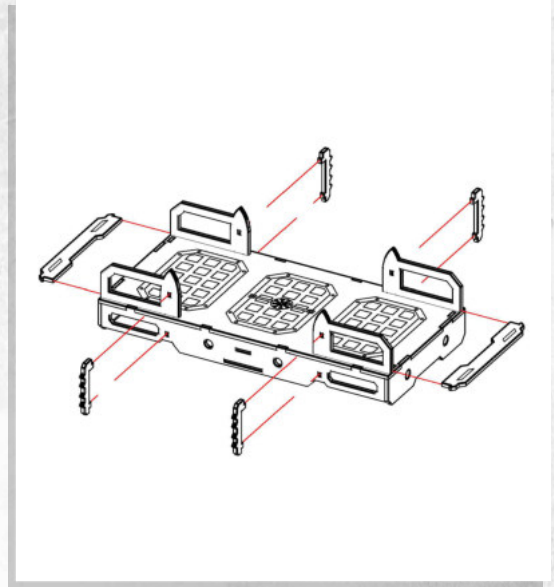

Walkway Assembly 2

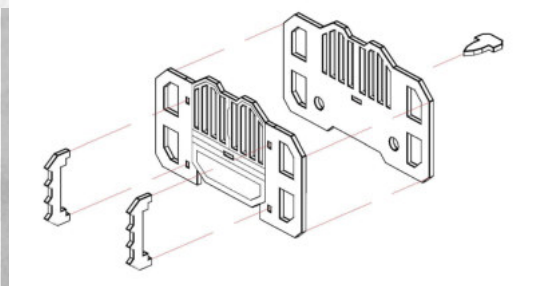

X2

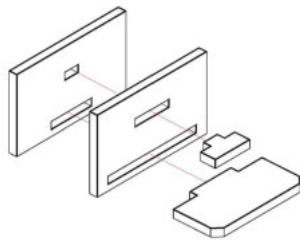

Accessory Assembly

- Gate
- Component Support x 2

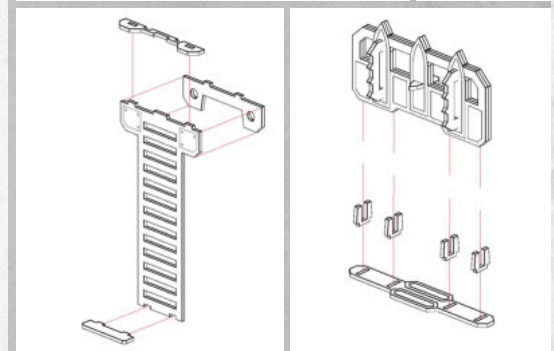
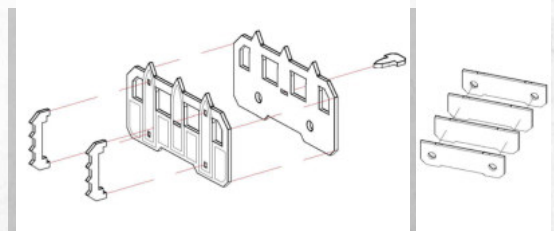

Accessory Assembly

- Barrier
- Magnet Polarity Adapter
- Ladder
- Barrier Stand



Dark Assembly Bridge - Assembly Guide

Parts may need careful removal from the MDF boards with a scalpel, and light sanding of any rough edges. We recommend testing assembling sections before permanently gluing together.

X2

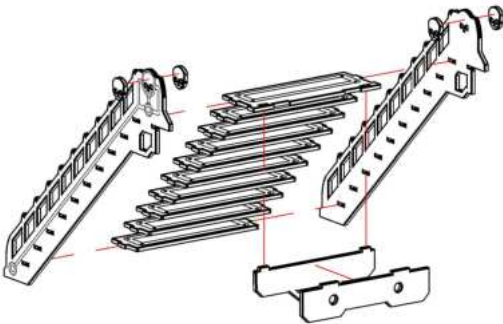

Step Assembly

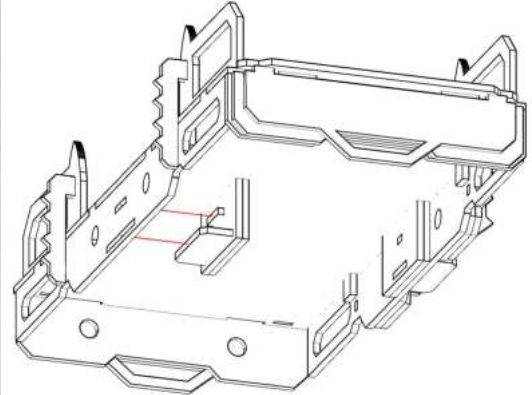

Component Support Placement

NOTE: These pieces provide additional support for some modular components from the Dark Assembly Range and therefore should be left un-glued and only used in configurations that require the additional support.

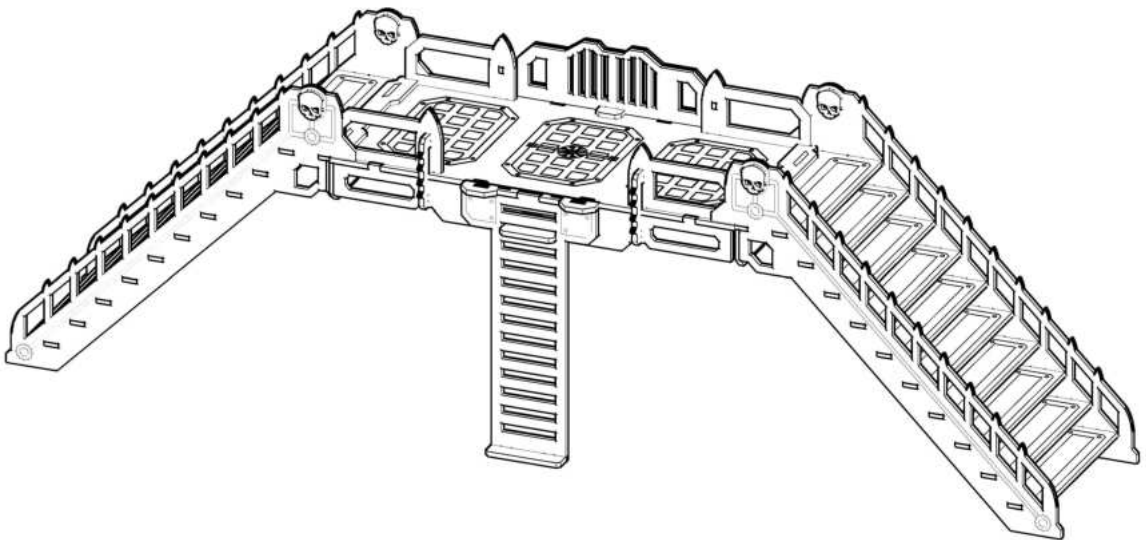

Example Configuration

The individual components may be glued in a fixed configuration, or alternatively can be magnetized with 5x2mm magnets using the provided holes.