

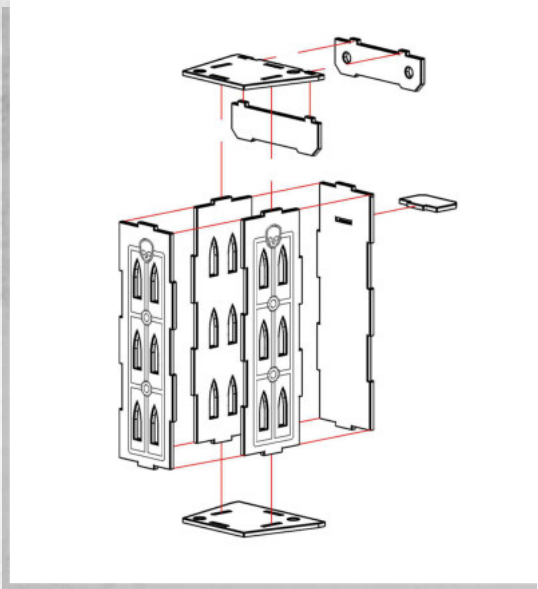

## Dark Assembly Tower - Assembly Guide

Parts may need careful removal from the MDF boards with a scalpel, and light sanding of any rough edges. We recommend testing assembling sections before permanently gluing together.



Tower Assembly

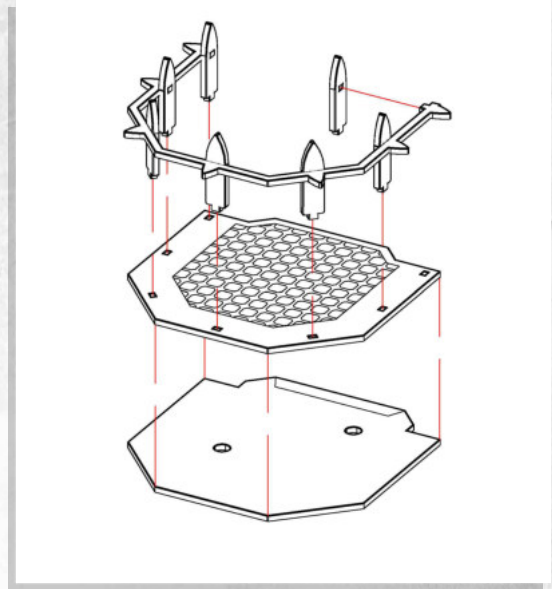

Tower Topper Assembly

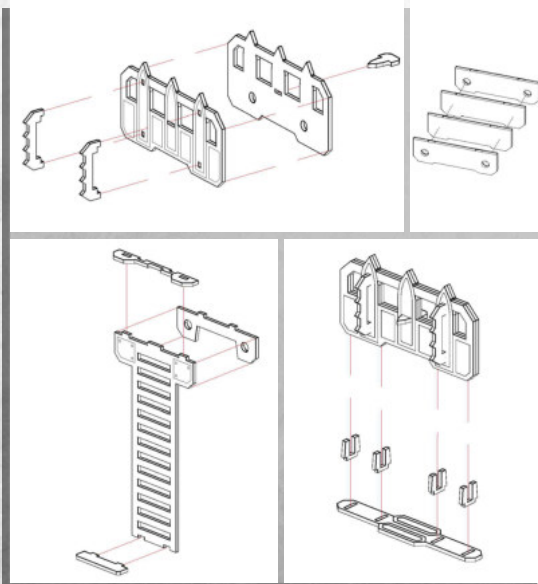

Accessory Assembly

- Barrier
- Magnet Polarity Adapter
- Ladder
- Barrier Stand



Example Configuration

The individual components may be glued in a fixed configuration, or alternatively can be magnetized with 5x2mm magnets using the provided holes.

