

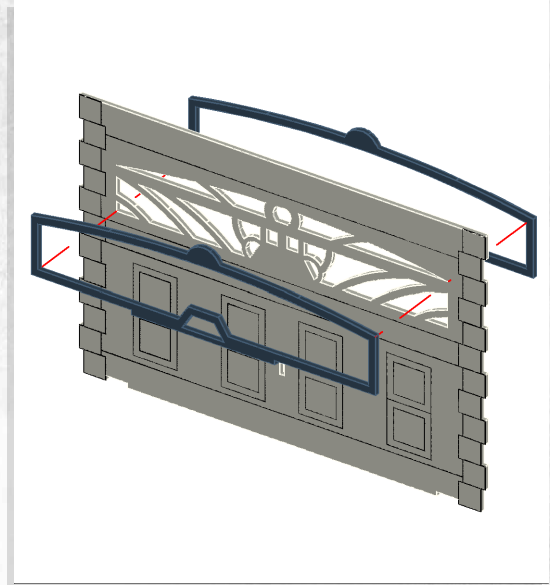

WARCRADLE<sup>TM</sup>  
SCENICS

## Myskham - Firestation - Assembly Guide

Warning: Pushing parts out by hand may cause damage. Parts may need careful removal from the MDF boards with a scalpel, and light sanding of any rough edges. We recommend testing assembling sections before permanently gluing together.

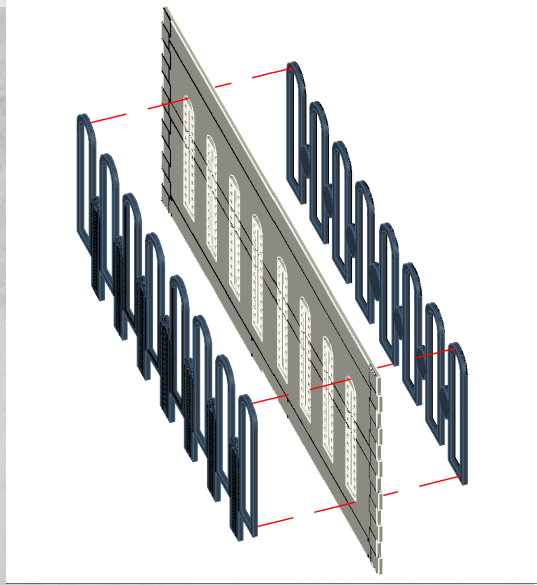

Note: Repeat for both

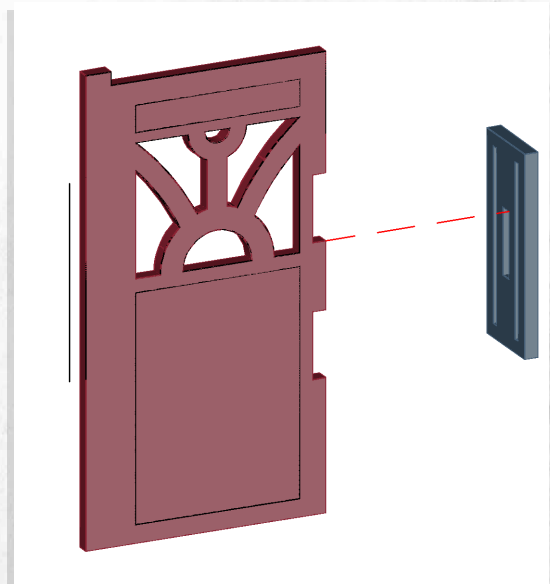
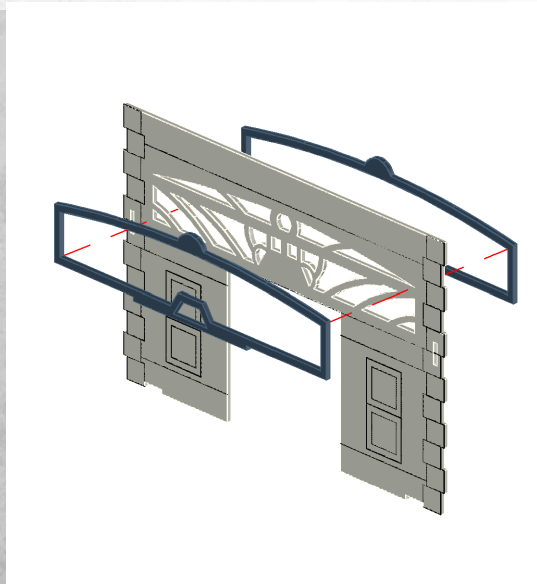

Note: Repeat for both



WARCRADLE<sup>TM</sup>  
SCENICS

## Myskham - Firestation - Assembly Guide

Warning: Pushing parts out by hand may cause damage. Parts may need careful removal from the MDF boards with a scalpel, and light sanding of any rough edges. We recommend testing assembling sections before permanently gluing together.

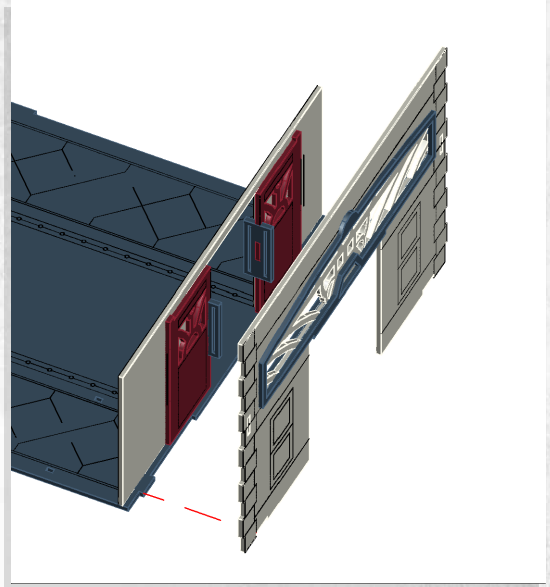
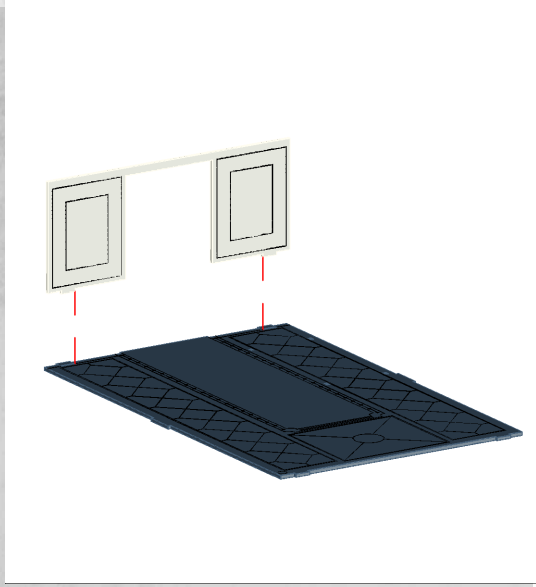

Note: DO NOT glue the doors

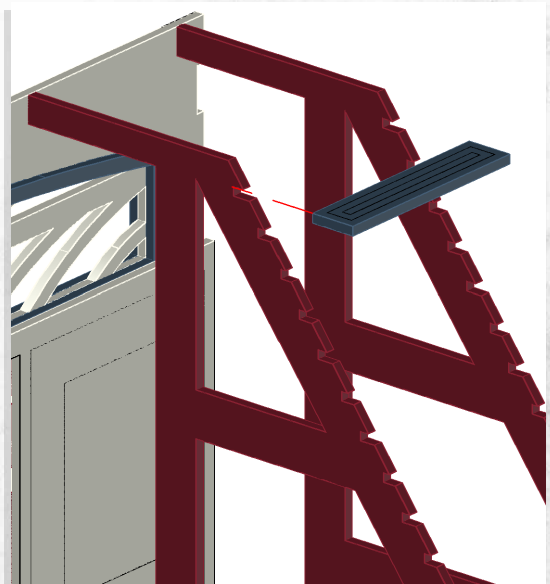
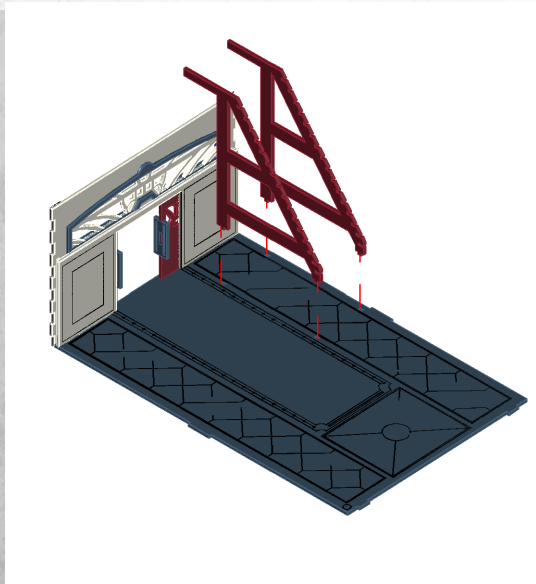

Note: Repeat for all steps



WARCRADLE<sup>TM</sup>  
SCENICS

## Myskham - Firestation - Assembly Guide

Warning: Pushing parts out by hand may cause damage. Parts may need careful removal from the MDF boards with a scalpel, and light sanding of any rough edges. We recommend testing assembling sections before permanently gluing together.

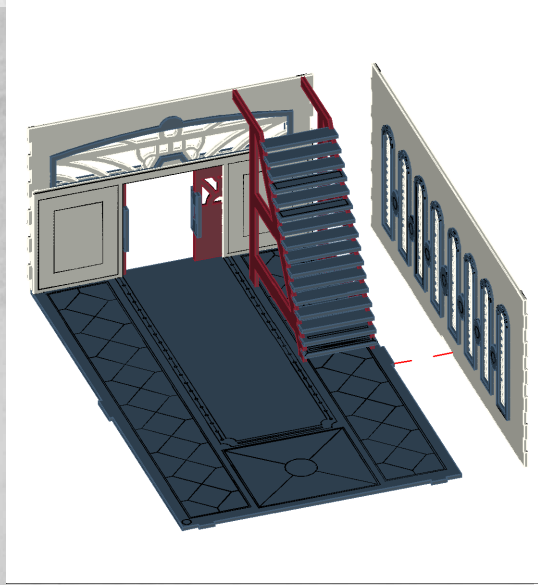

Note: Repeat for both walls

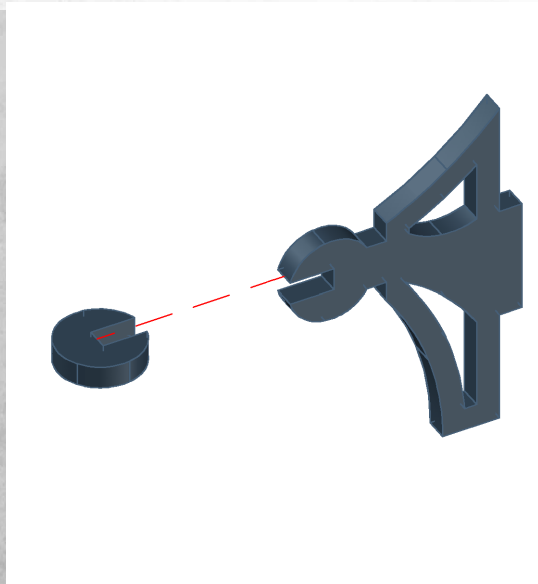
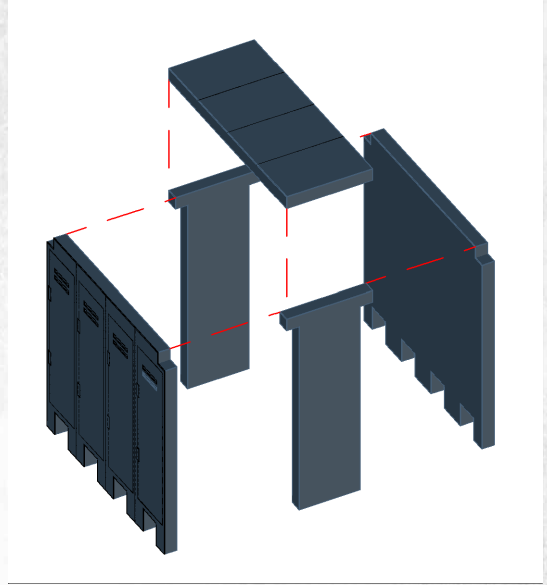

Note: Repeat for all





WARCRADLE<sup>TM</sup>  
SCENICS

## Myskham - Firestation - Assembly Guide

Warning: Pushing parts out by hand may cause damage. Parts may need careful removal from the MDF boards with a scalpel, and light sanding of any rough edges. We recommend testing assembling sections before permanently gluing together.

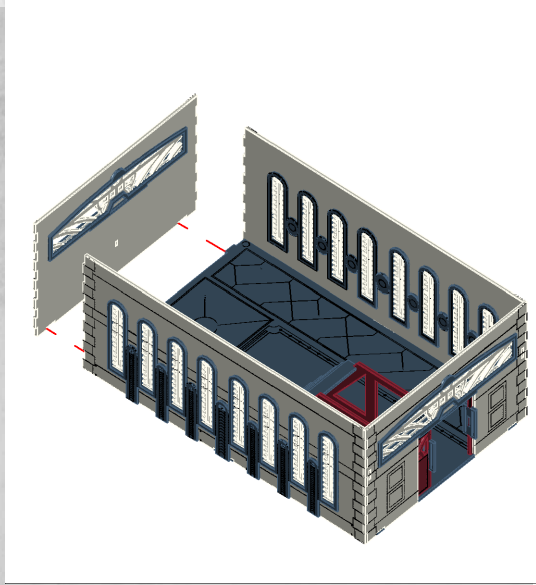

Note: Repeat for both walls

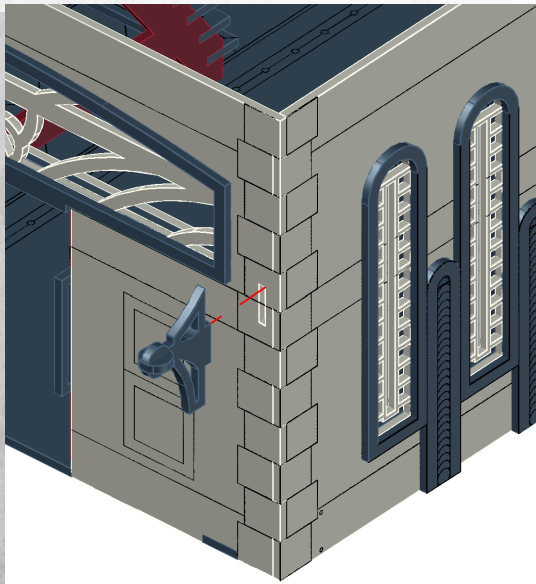
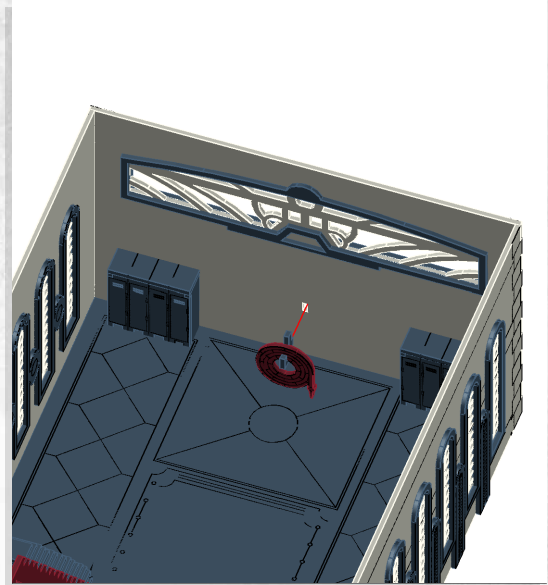

Note: Repeat for all around building

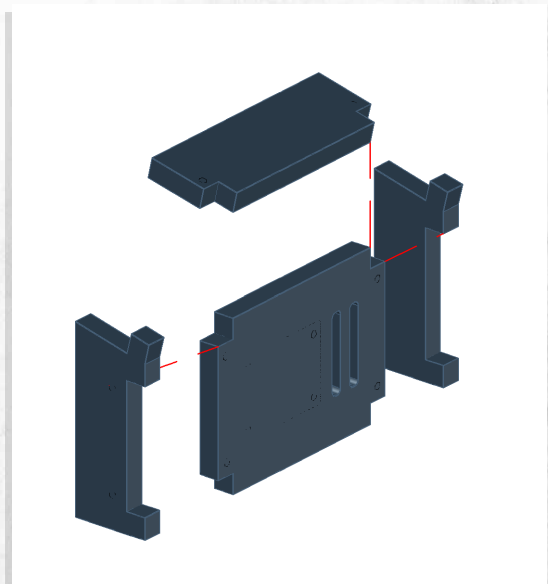

## Myskham - Firestation - Assembly Guide

Warning: Pushing parts out by hand may cause damage. Parts may need careful removal from the MDF boards with a scalpel, and light sanding of any rough edges. We recommend testing assembling sections before permanently gluing together.

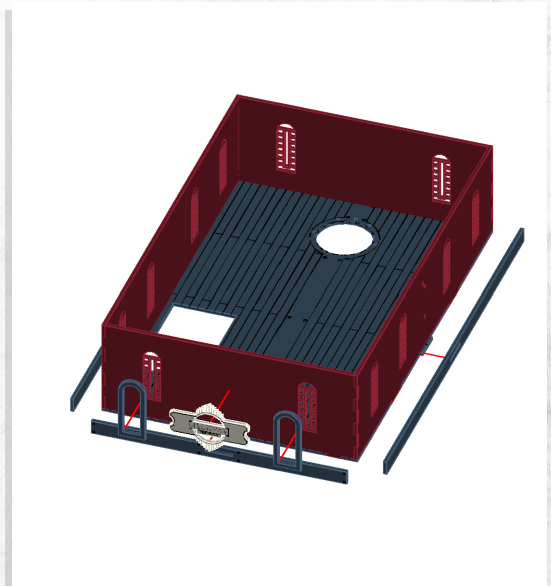
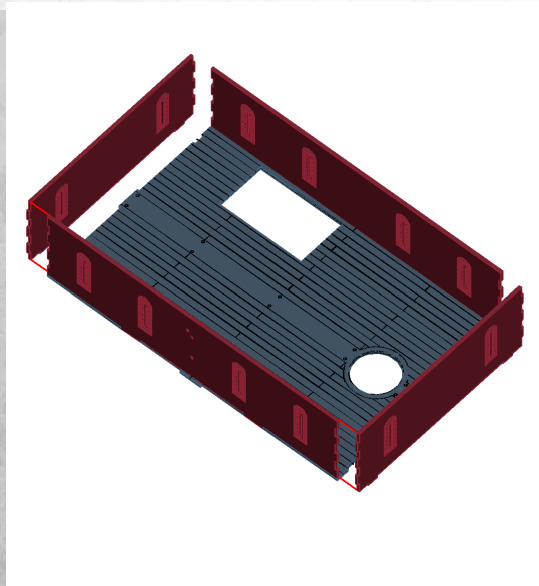
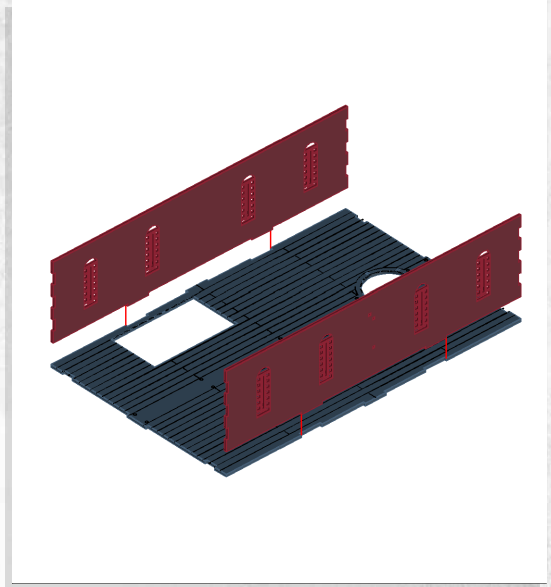
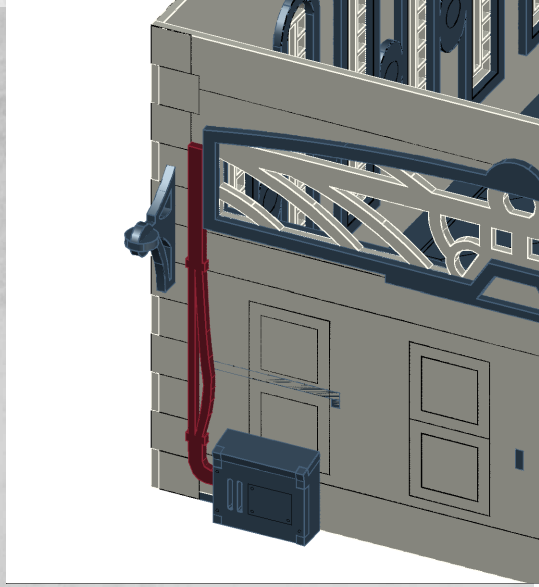

Note: Repeat window frames for all around building





WARCRADLE<sup>TM</sup>  
SCENICS

## Myskham - Firestation - Assembly Guide

Warning: Pushing parts out by hand may cause damage. Parts may need careful removal from the MDF boards with a scalpel, and light sanding of any rough edges. We recommend testing assembling sections before permanently gluing together.

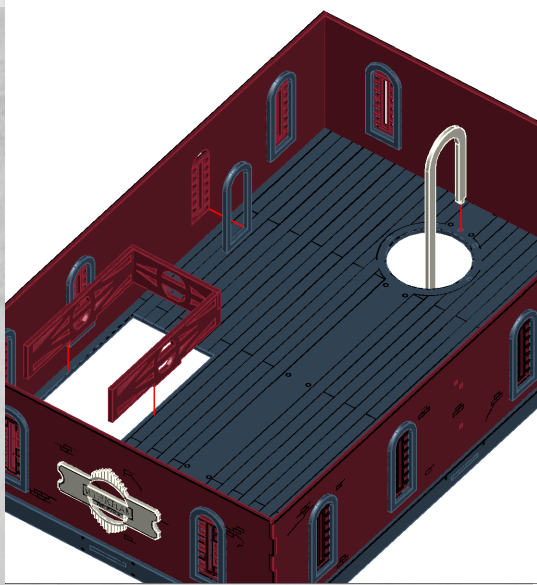

Note: Repeat window frames for all inside building

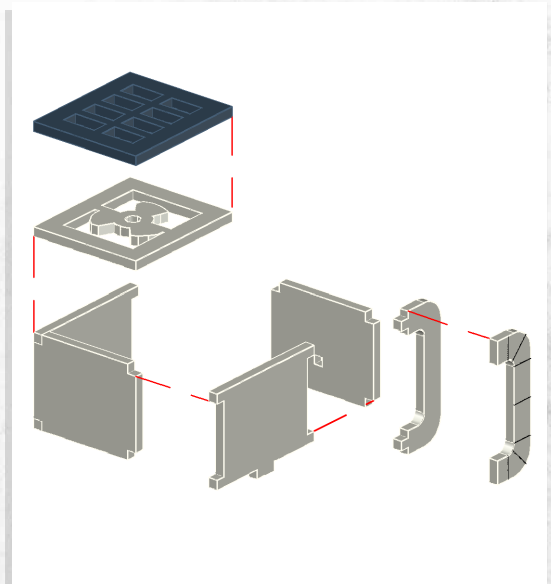
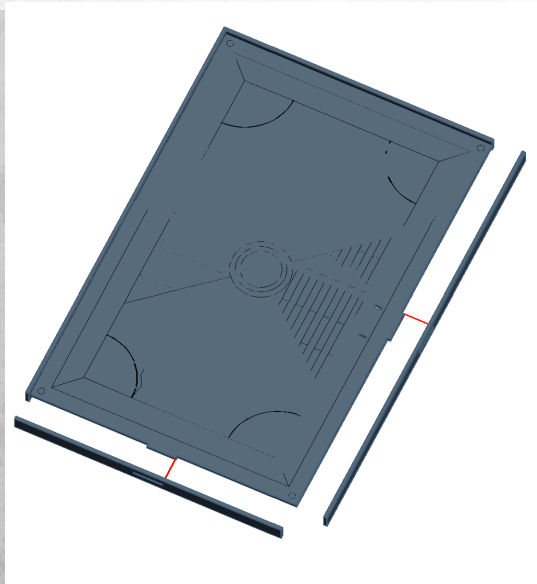
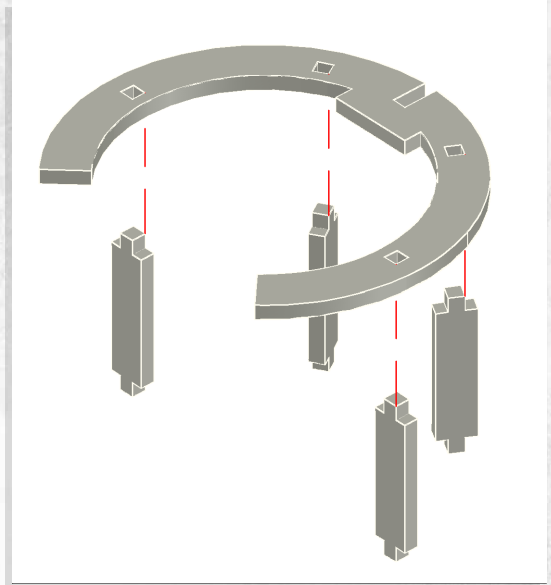



WARCRADLE<sup>TM</sup>  
SCENICS

## Myskham - Firestation - Assembly Guide

Warning: Pushing parts out by hand may cause damage. Parts may need careful removal from the MDF boards with a scalpel, and light sanding of any rough edges. We recommend testing assembling sections before permanently gluing together.

