

TOPKAPI CLASS BATTLESHIP BRIDGE

PARTS CAN BE FOUND ON THE SULTANATE SUPPORT SQUADRONS SPRUES

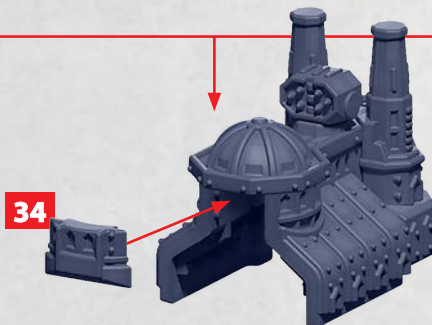
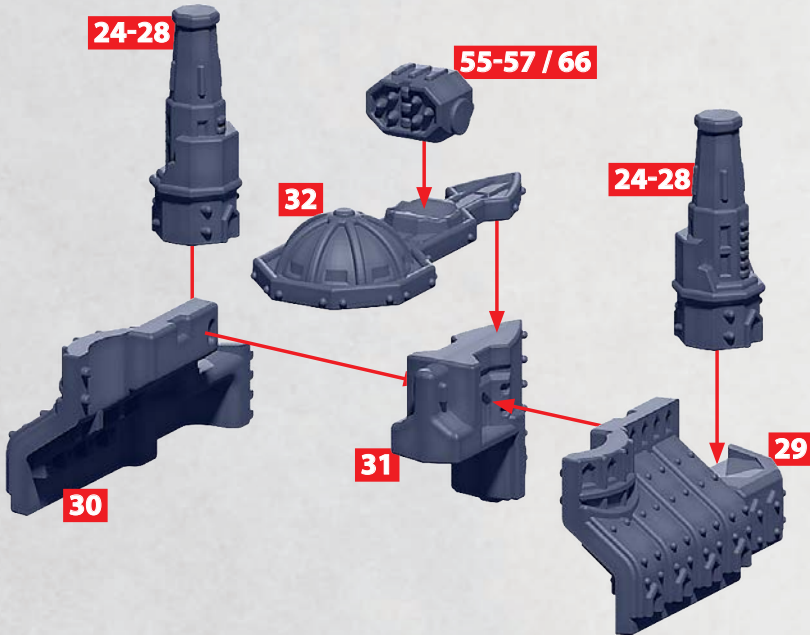

TOPKAPI CLASS BATTLESHIP HULL

PARTS CAN BE FOUND ON THE SULTANATE SUPPORT SQUADRONS SPRUES

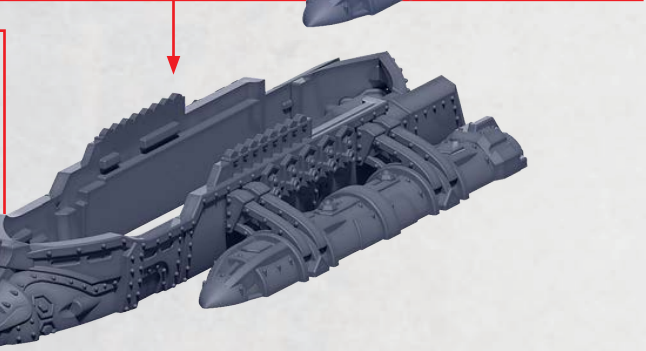
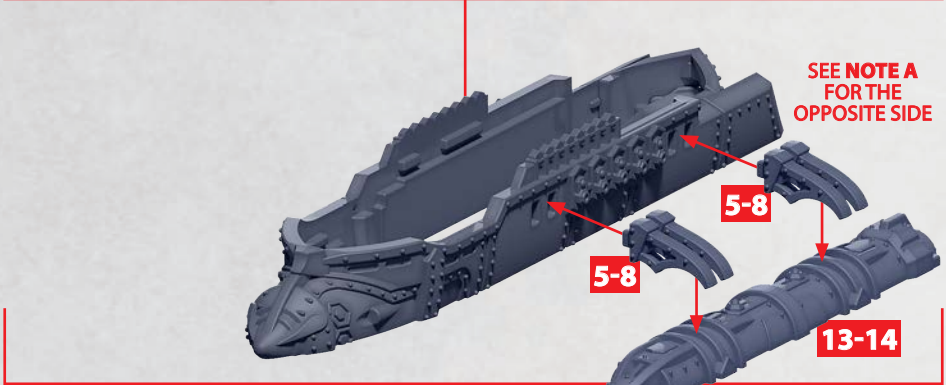
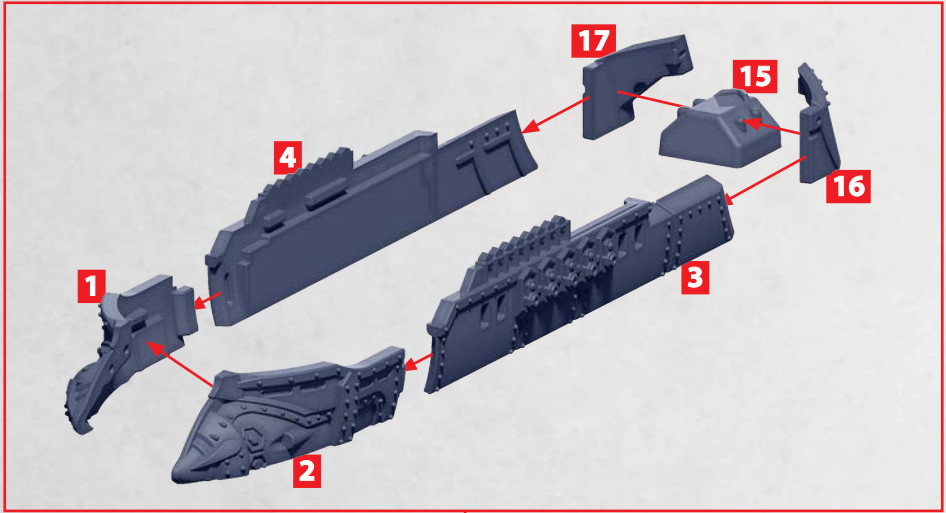

TOPKAPI CLASS BATTLESHIP

PARTS CAN BE FOUND ON THE SULTANATE FRONLINE SQUADRONS SPRUES



SEE PAGE 1
FOR ASSEMBLY

SEE NOTE A
FOR THE
OPPOSITE SIDE



18

36

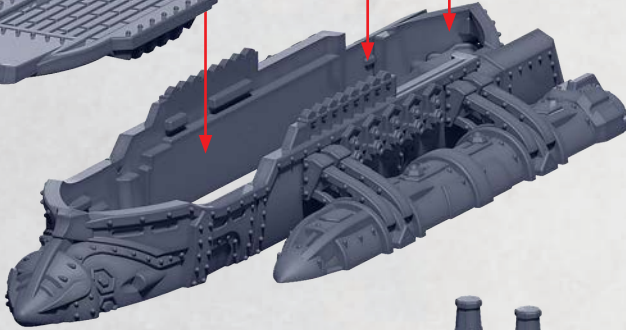
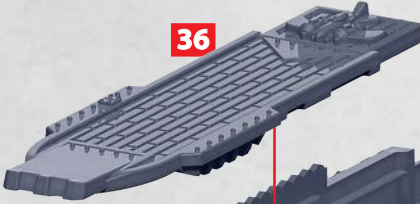

**NOTE A: FOR RIGHT SIDE
HULL SECTION BUILD
AS MIRRORED VERSION**

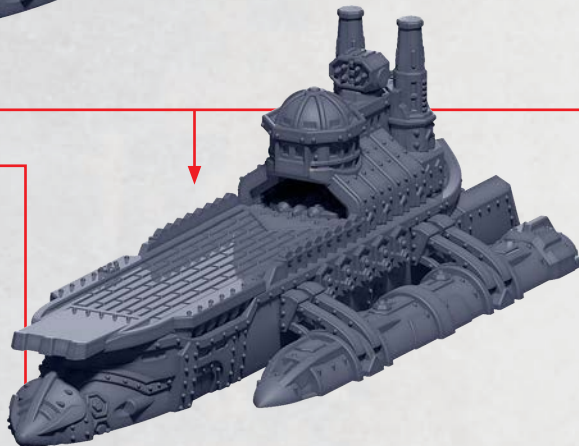

TOPKAPI CLASS BATTLESHIP

PARTS CAN BE FOUND AS RESIN PARTS

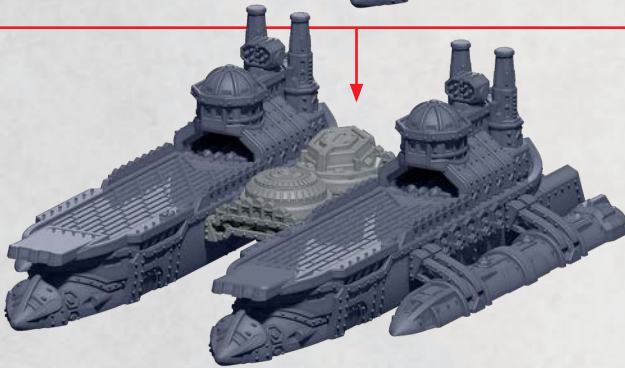
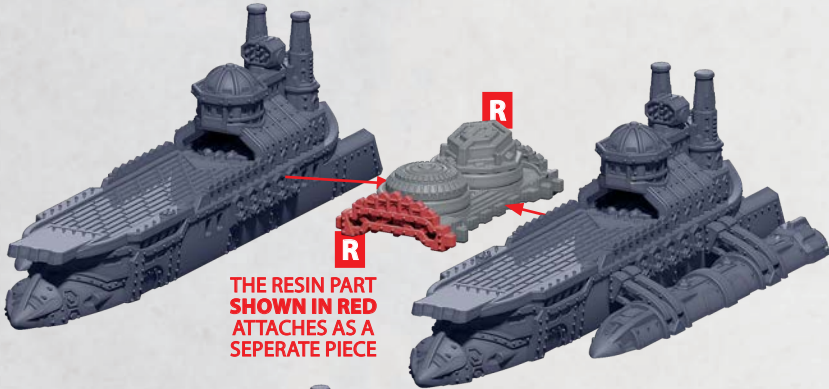

ESCORT SKIFF

PARTS CAN BE FOUND ON THE SULTANATE SUPPORT SQUADRON SPRUES

