

ENLIGHTENED ESCORT

PLASTIC PARTS CAN BE FOUND ON THE ENLIGHTENED ADVANCED SQUADRONS SPRUES

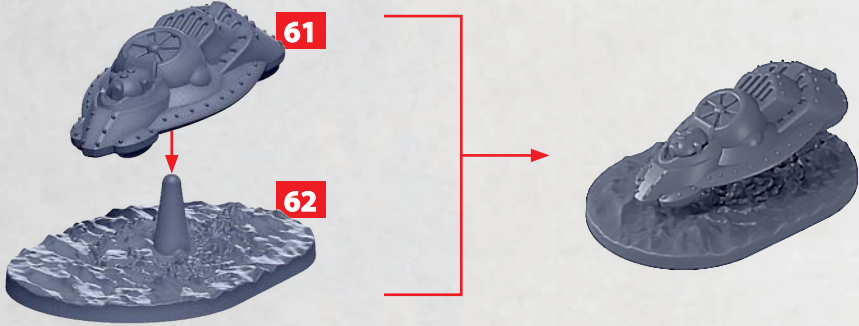

KETOS OR LOTAN CLASS ASSAULT MACHINE

PLASTIC PARTS CAN BE FOUND ON THE ENLIGHTENED ADVANCED SQUADRONS SPRUES

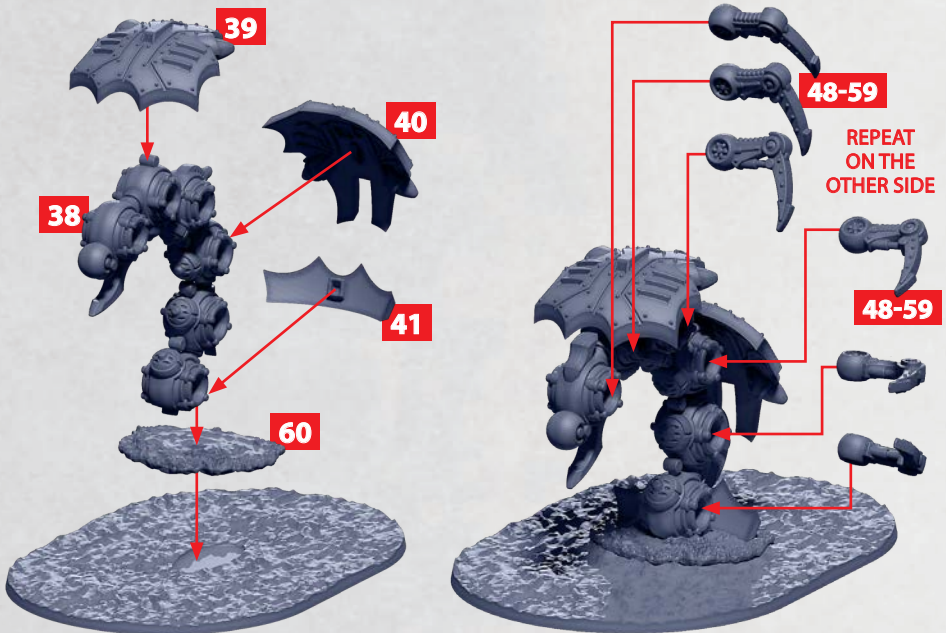

KETOS CLASS ASSAULT MACHINE

PLASTIC PARTS CAN BE FOUND ON THE ENLIGHTENED ADVANCED SQUADRONS SPRUES



LOTAN CLASS ASSAULT MACHINE

PLASTIC PARTS CAN BE FOUND ON THE ENLIGHTENED ADVANCED SQUADRONS SPRUES



ADVANCED CRUISER HULL

PLASTIC PARTS CAN BE FOUND ON THE ENLIGHTENED ADVANCED SQUADRONS SPRUES



6

**PLEASE NOTE: THE VARIOUS
BRIDGE SECTION ASSEMBLED
FROM PAGES 4-7 MUST BE
ATTACHED TO THE SIDE
ELEMENTS (5 & 6) THEN FIXED
TO THE DECK (7) PRIOR TO
ATTACHING EACH SIDES OF
THE HULL (1 & 2 BELOW)**



5

**SIDE A FOR
NEWTON
AND
ORIGEN
CLASS SHIPS**



8



7

**SIDE B FOR
VESALIUS
AND
ZUMEENA
CLASS SHIPS**

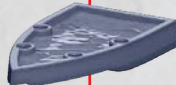

4

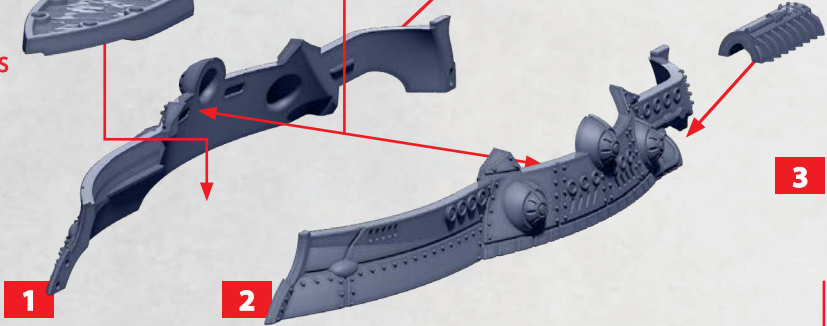

1

2

3

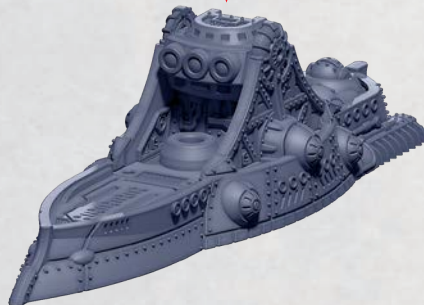

ORIGEN CLASS LATHE SHIP

PLASTIC PARTS CAN BE FOUND ON THE ENLIGHTENED ADVANCED SQUADRONS SPRUES

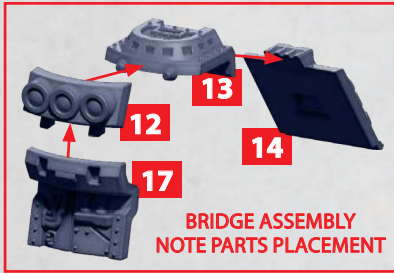

180°
ROTATED



180°
ROTATED

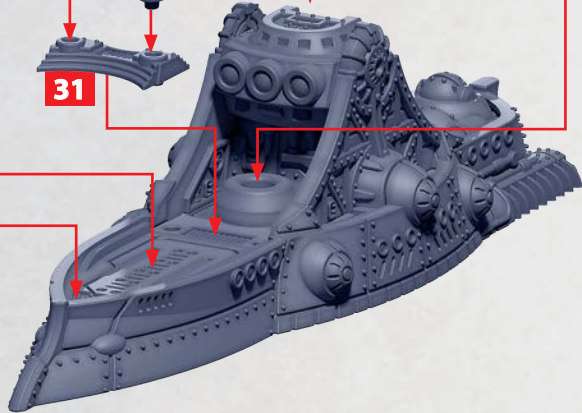

NEWTON CLASS VOID-ENGINE CRUISER

PLASTIC PARTS CAN BE FOUND ON THE ENLIGHTENED ADVANCED SQUADRONS SPRUES

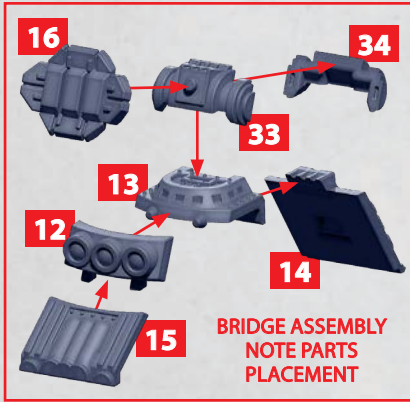

180°
ROTATED



180°
ROTATED

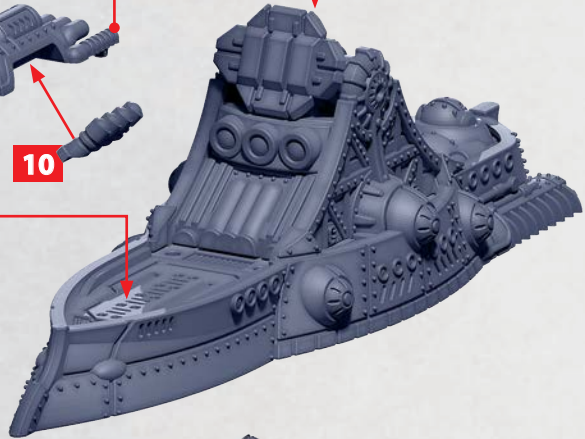
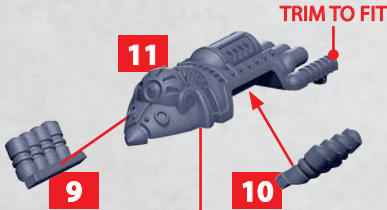

VESALIUS CLASS CETACEAN SURGICAL SHIP

PLASTIC PARTS CAN BE FOUND ON THE ENLIGHTENED ADVANCED SQUADRONS SPRUES

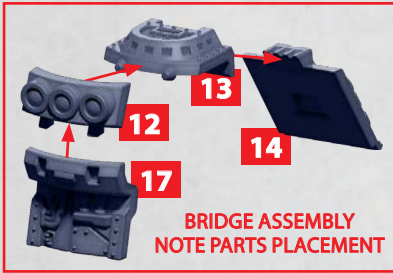

180°
ROTATED



23

180°
ROTATED

25-30

24

25-30

25-30

25-30

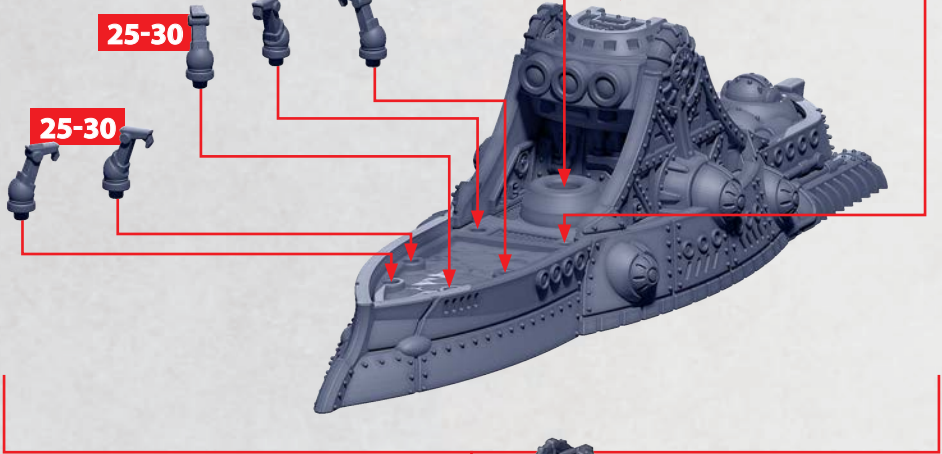

ZUMEENA CLASS CAPACITOR SHIP

PLASTIC PARTS CAN BE FOUND ON THE ENLIGHTENED ADVANCED SQUADRONS SPRUES



180°
ROTATED

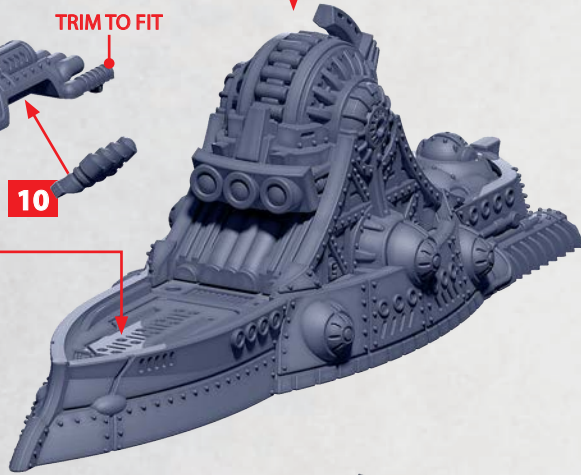
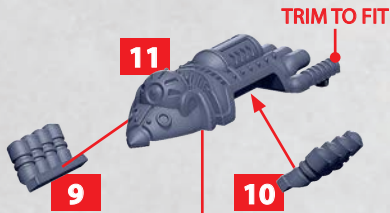

VITRUVIAN COLOSSUS BODY

PARTS CAN BE FOUND ON THE MARENA COLOSSAL SPRUES

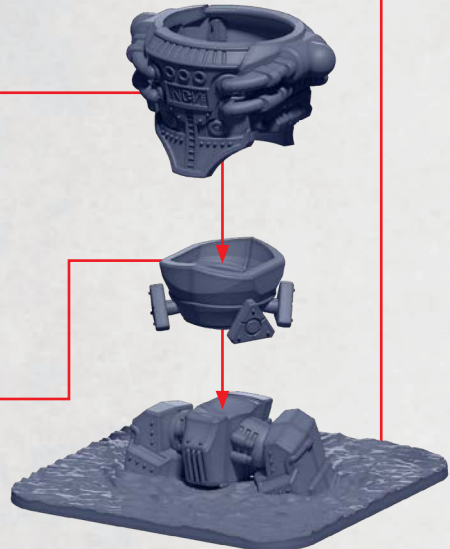
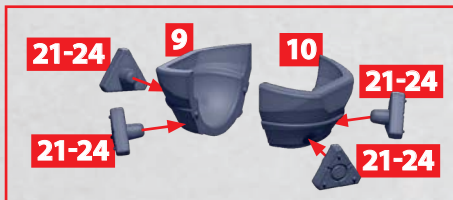
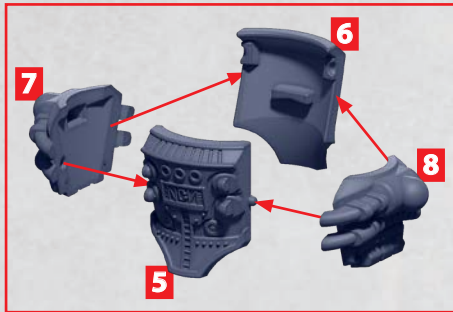
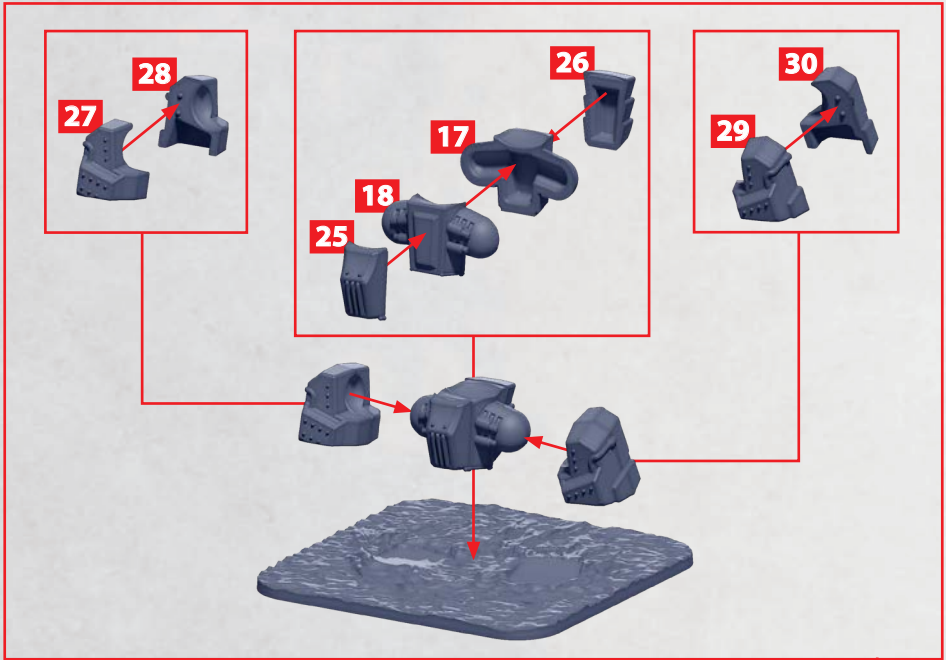

VITRUVIAN COLOSSUS BODY

PARTS CAN BE FOUND ON THE MARENA COLOSSAL SPRUES

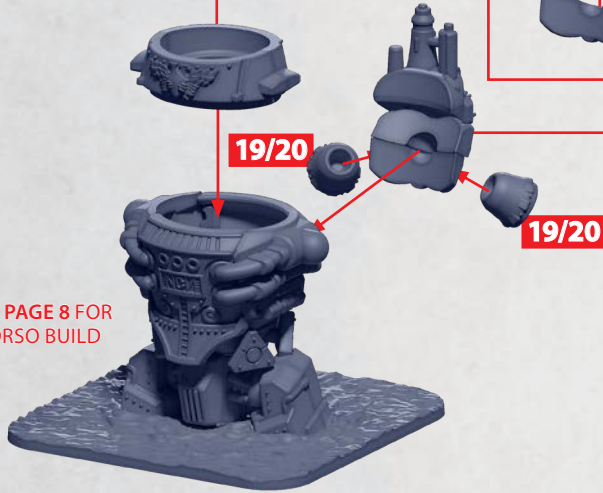
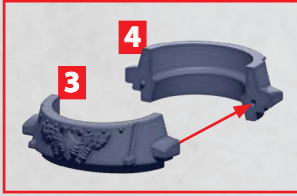

SEE PAGE 8 FOR
TORSO BUILD



VITRUVIAN COLOSSUS BODY

PARTS CAN BE FOUND ON THE MARENA COLOSSAL SPRUES



SEE PAGE 9 FOR
TORSO BUILD



MARENA VITRUVIAN COLOSSUS

PARTS CAN BE FOUND ON THE MARENA COLOSSAL SPRUES



KOSTROMA VITRUVIAN COLOSSUS

PARTS CAN BE FOUND ON THE MARENA COLOSSAL SPRUES

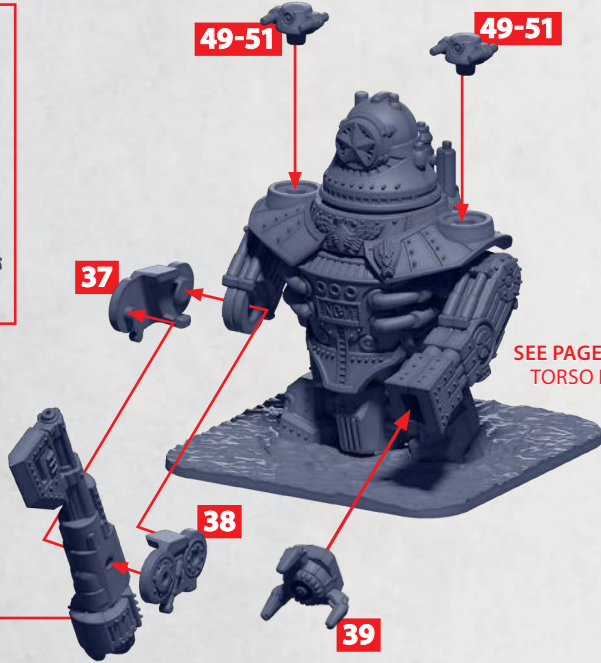

BOYAR HEAVY FRIGATE

PARTS CAN BE FOUND ON THE MARENA COLOSSAL SPRUES

