

# OLYMPIA CONVEYOR LOWER BOW, HULL & STERN

PARTS CAN BE FOUND ON THE TITAN CLASS HEAVY CONVEYOR SPRUES

**!! IMPORTANT !!**  
PICK REQUIRED BUILD (TITAN OR OLYMPIA CLASS) ON PAGES 22-27, BEFORE ANY ASSEMBLY

COMPLETED SINGLE BODY VESSEL HULL – CONSIDER THE POSITION OF FLIGHT STAND BEFORE ANY ASSEMBLY

**NOTE:** ON DOUBLE BODY VESSELS, ONE SECTION WILL NOT REQUIRE (RED) PART 2-4 AT THE FRONT OR BACK, DEPENDING WHERE YOU PLACE THE SECTION



PARTS 40 WILL ONLY REQUIRE PART 42-43 IN ONE SECTION WHEN ASSEMBLING THE DOUBLE BODY VESSEL (NOT REQUIRED ON SINGLE HULL VERSION) – CONSIDER THE POSITION OF FLIGHT STAND BEFORE ANY ASSEMBLY

\* HOLE FOR FLIGHT STAND  
42-43

THE EXTRA SECTION FOR THE DOUBLE BODY VESSEL CAN BE ROTATED TO FIT EITHER THE FRONT OR BACK OF THE SINGLE SECTION (FAR LEFT) – CONSIDER THE POSITION OF FLIGHT STAND BEFORE ANY ASSEMBLY

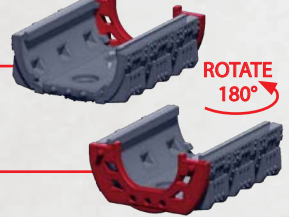

# TITAN & OLYMPIA CONVEYOR UPPER BOW & STERN

PARTS CAN BE FOUND ON THE TITAN CLASS HEAVY CONVEYOR SPRUES

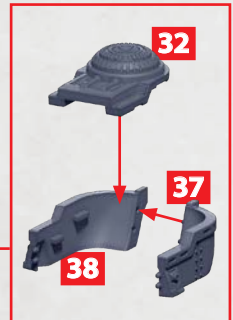
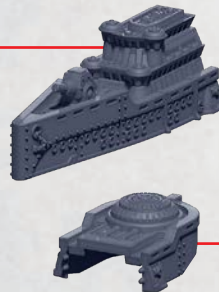
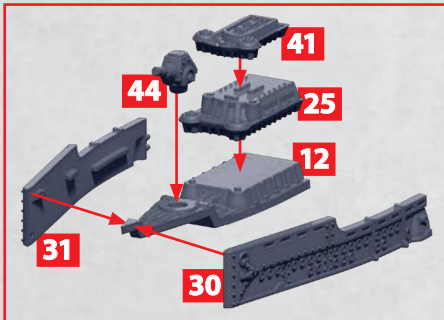

# TITAN AND OLYMPIA CONVEYOR CARGO

PARTS CAN BE FOUND ON THE **TITAN CLASS HEAVY CONVEYOR** SPRUES

## SINGLE BODY VESSEL (OR FRONT OF DOUBLE BODY VESSEL)

**NOTE:** THE SINGLE BODY VESSEL ONLY REQUIRES PART 7 (INDICATED RED) – IF PART OF THE DOUBLE BODY VESSEL THEN PART 7 IS OMITTED HERE

## DOUBLE BODY VESSEL ONLY (REAR SECTION)

**NOTE:** WHEN CONSTRUCTING A DOUBLE BODY VESSEL THEN PART 7 (INDICATED RED) MOVES TO THE REAR OF THIS SECTION – SEE NOTE LEFT

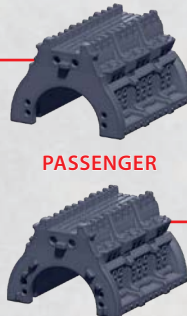

\*REPEAT ATTACHMENT OF PARTS 49-52 ON OPPOSITE SIDE OF MODEL

# TITAN AND OLYMPIA CONVEYOR UPPER ASSEMBLY

PARTS CAN BE FOUND ON THE **TITAN CLASS HEAVY CONVEYOR SPRUES**

CAN BE BUILT AS EITHER **SINGLE**  
OR **DOUBLE** BODY MODELS

SEE PAGE 2 FOR CARGO BUILD  
(OIL, PASSENGER OR FREIGHT) OPTIONS

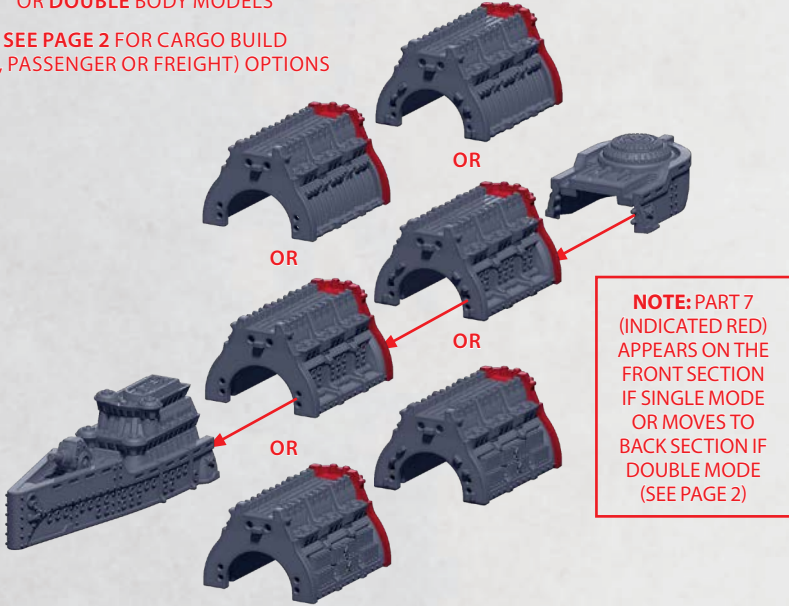

BOTH EXAMPLES BELOW SHOWN WITH PASSENGER CARGO SECTIONS

**SINGLE BODY  
VESSEL**

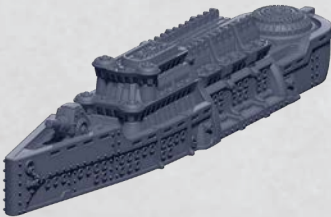

**DOUBLE BODY  
VESSEL**

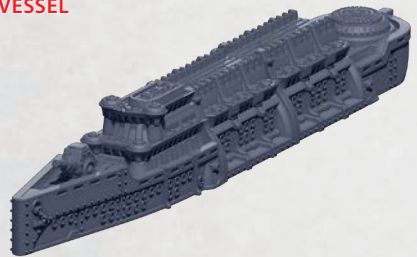

# OLYMPIA CONVEYOR LOWER ASSEMBLY

PARTS CAN BE FOUND ON THE **TITAN CLASS HEAVY CONVEYOR** SPRUES

RECOMMENDED  
POSITION OF FLIGHT  
STAND FOR **SINGLE  
HULL VESSEL** IS  
THE FRONT OF THE  
SECTION TOWARD  
THE BOW

RECOMMENDED  
POSITION OF FLIGHT  
STAND FOR **DOUBLE  
HULL VESSEL** IS THE  
REAR OF THE FRONT  
HULL SECTION  
TOWARD THE CENTRE

CAN BE BUILT AS EITHER **SINGLE**  
OR **DOUBLE** BODY MODELS

SEE PAGE 1 FOR ASSEMBLY  
OF EACH SECTION

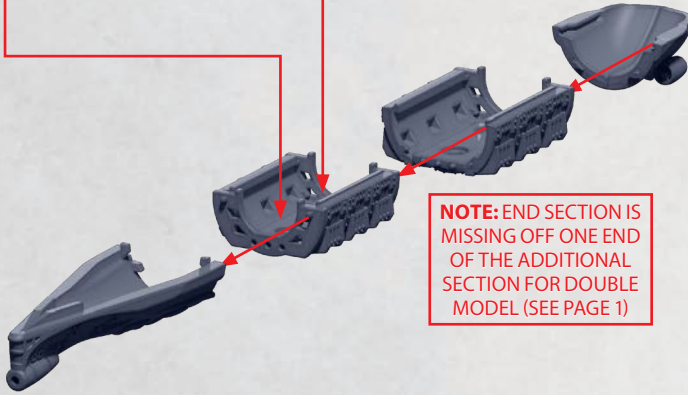

**NOTE:** END SECTION IS  
MISSING OFF ONE END  
OF THE ADDITIONAL  
SECTION FOR DOUBLE  
MODEL (SEE PAGE 1)

**SINGLE BODY  
VESSEL**

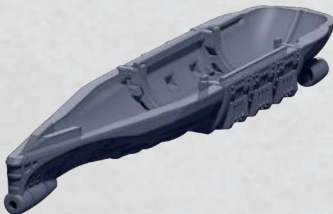

**DOUBLE BODY  
VESSEL**



# TITAN CONVEYOR PASSENGER

PARTS CAN BE FOUND ON THE **TITAN CLASS HEAVY CONVEYOR** SPRUES

FUNNELS

36

35

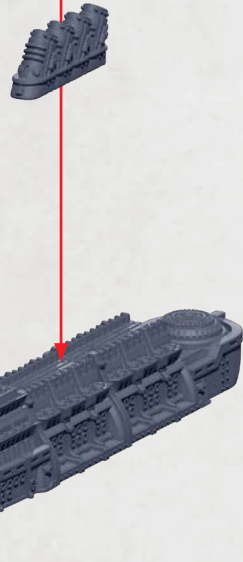
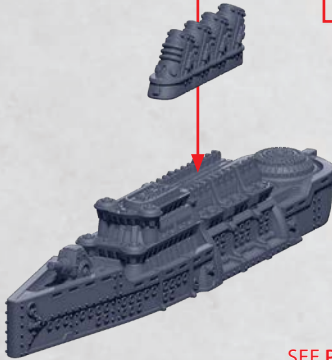

SEE PAGES 1-3  
FOR ASSEMBLY

SINGLE BODY  
VESSEL

DOUBLE BODY  
VESSEL

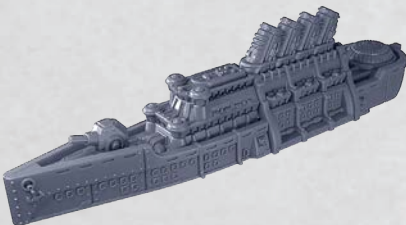

# OLYMPIA CONVEYOR PASSENGER

PARTS CAN BE FOUND ON THE TITAN CLASS HEAVY CONVEYOR SPRUES



SEE PAGE 5  
FOR FUNNEL  
ASSEMBLY AND  
ATTACHEMENT

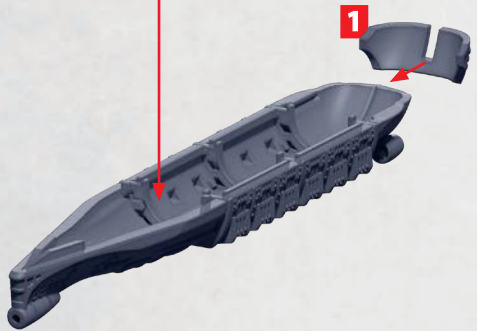
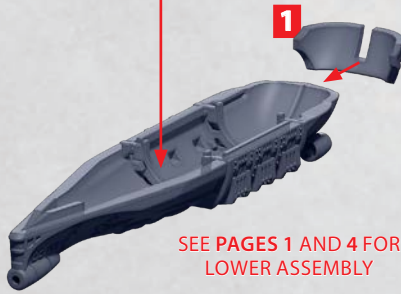
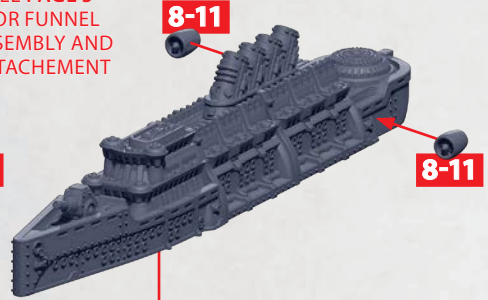

SINGLE BODY  
VESSEL

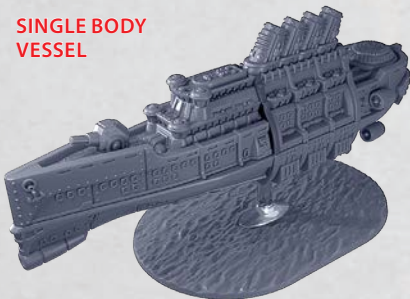

DOUBLE BODY  
VESSEL



# TITAN CONVEYOR OIL

PARTS CAN BE FOUND ON THE **TITAN CLASS HEAVY CONVEYOR** SPRUES

CRANE

**60-61** OR **70**

**62-63** OR **66**

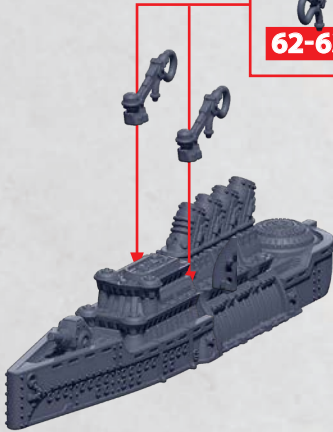

SEE PAGE 5  
FOR FUNNEL  
ASSEMBLY AND  
ATTACHMENT

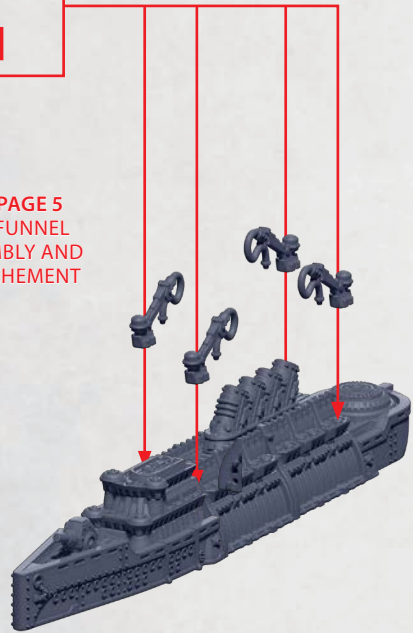

SEE PAGES 1-3  
FOR ASSEMBLY

SINGLE BODY  
VESSEL

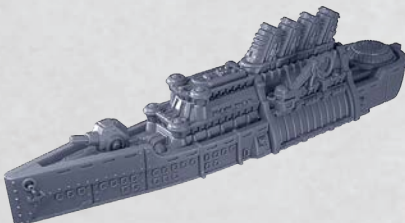

DOUBLE BODY  
VESSEL

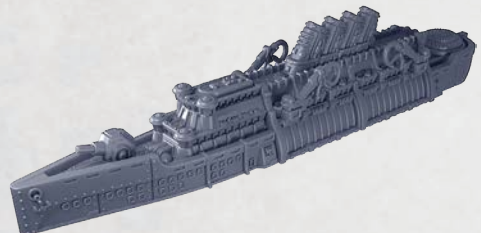

# OLYMPIA CONVEYOR OIL

PARTS CAN BE FOUND ON THE TITAN CLASS HEAVY CONVEYOR SPRUES

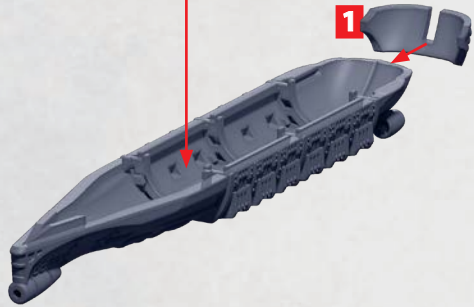
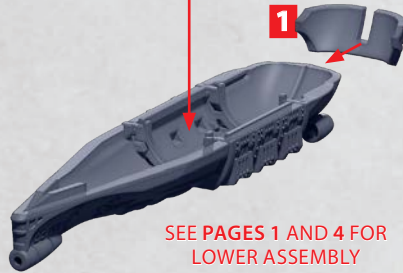
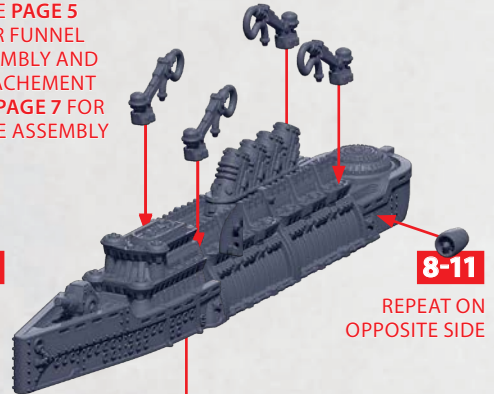
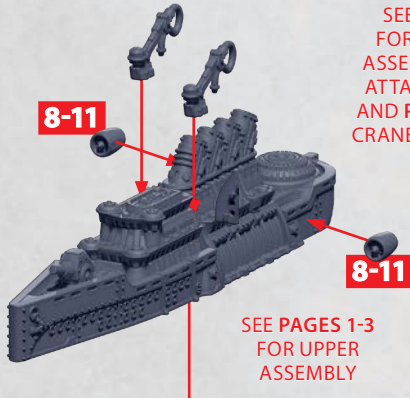

SINGLE BODY  
VESSEL



DOUBLE BODY  
VESSEL



# TITAN CONVEYOR FREIGHT

PARTS CAN BE FOUND ON THE TITAN CLASS HEAVY CONVEYOR SPRUES

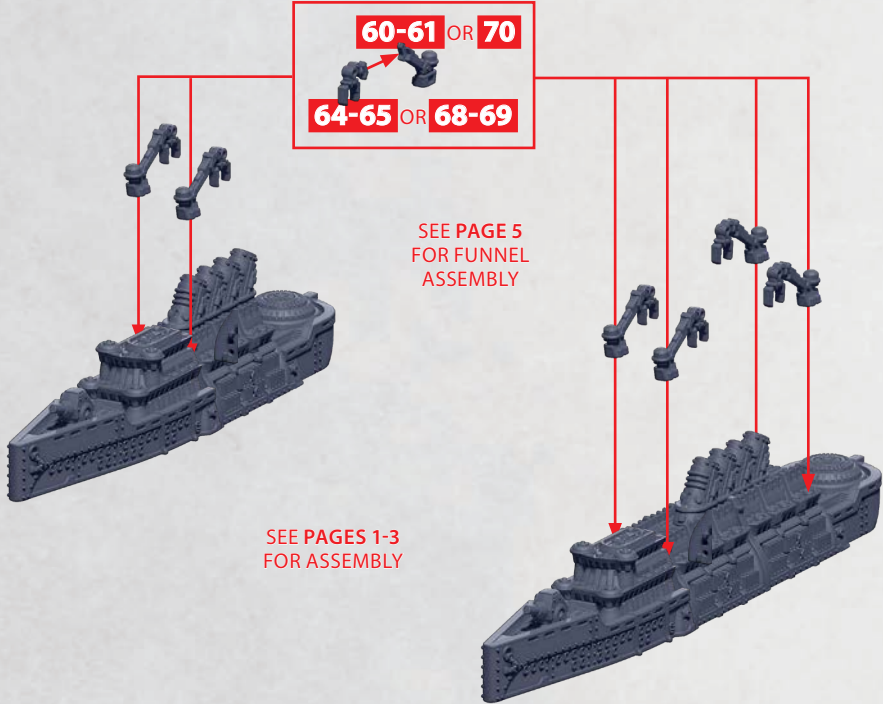

SEE PAGE 5  
FOR FUNNEL  
ASSEMBLY

SEE PAGES 1-3  
FOR ASSEMBLY

SINGLE BODY  
VESSEL

DOUBLE BODY  
VESSEL

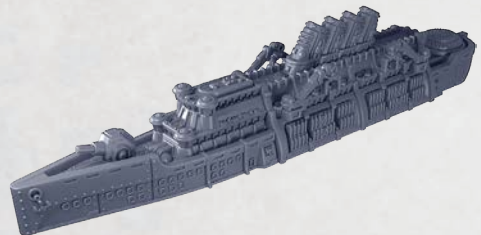

# OLYMPIA CONVEYOR FREIGHT

PARTS CAN BE FOUND ON THE TITAN CLASS HEAVY CONVEYOR SPRUES

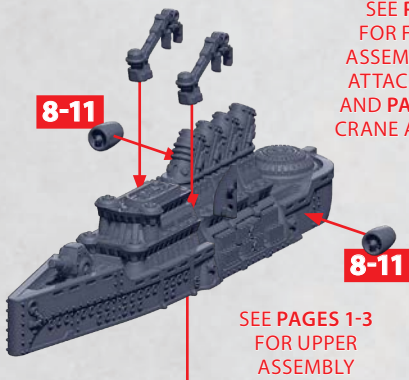

SEE PAGE 5  
FOR FUNNEL  
ASSEMBLY AND  
ATTACHEMENT  
AND PAGE 7 FOR  
CRANE ASSEMBLY

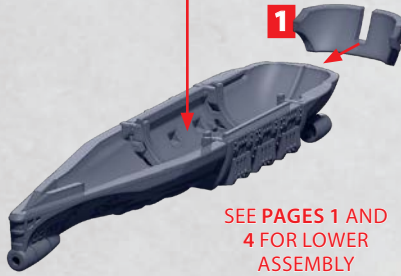
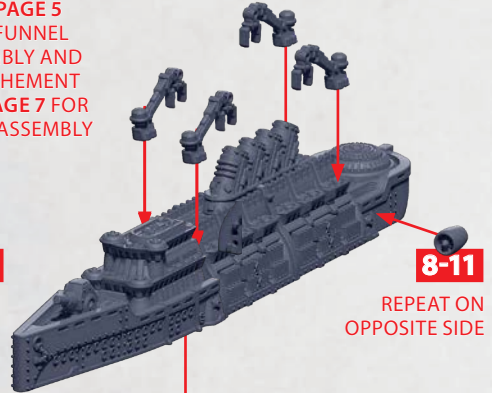

SINGLE BODY  
VESSEL

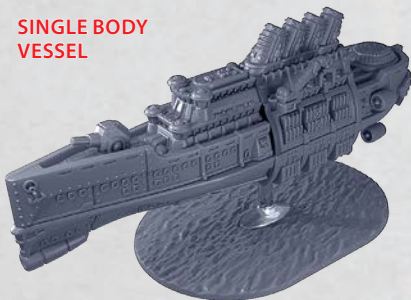

DOUBLE BODY  
VESSEL



# MERCHANT SHIP (HATCH, OIL & FREIGHT)

PARTS CAN BE FOUND ON THE TITAN CLASS HEAVY CONVEYOR SPRUES

HATCH

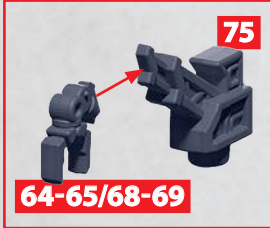

OIL



FREIGHT

